

# WILD HORSES

## FOUR WHEEL DRIVE

Phone (209) 400-7200 Fax (209) 943-7923 www.wildhorses4x4.com

### Rear Disk Brake Kit w/ E-Brake Cables

#3131 Date 02/21/19

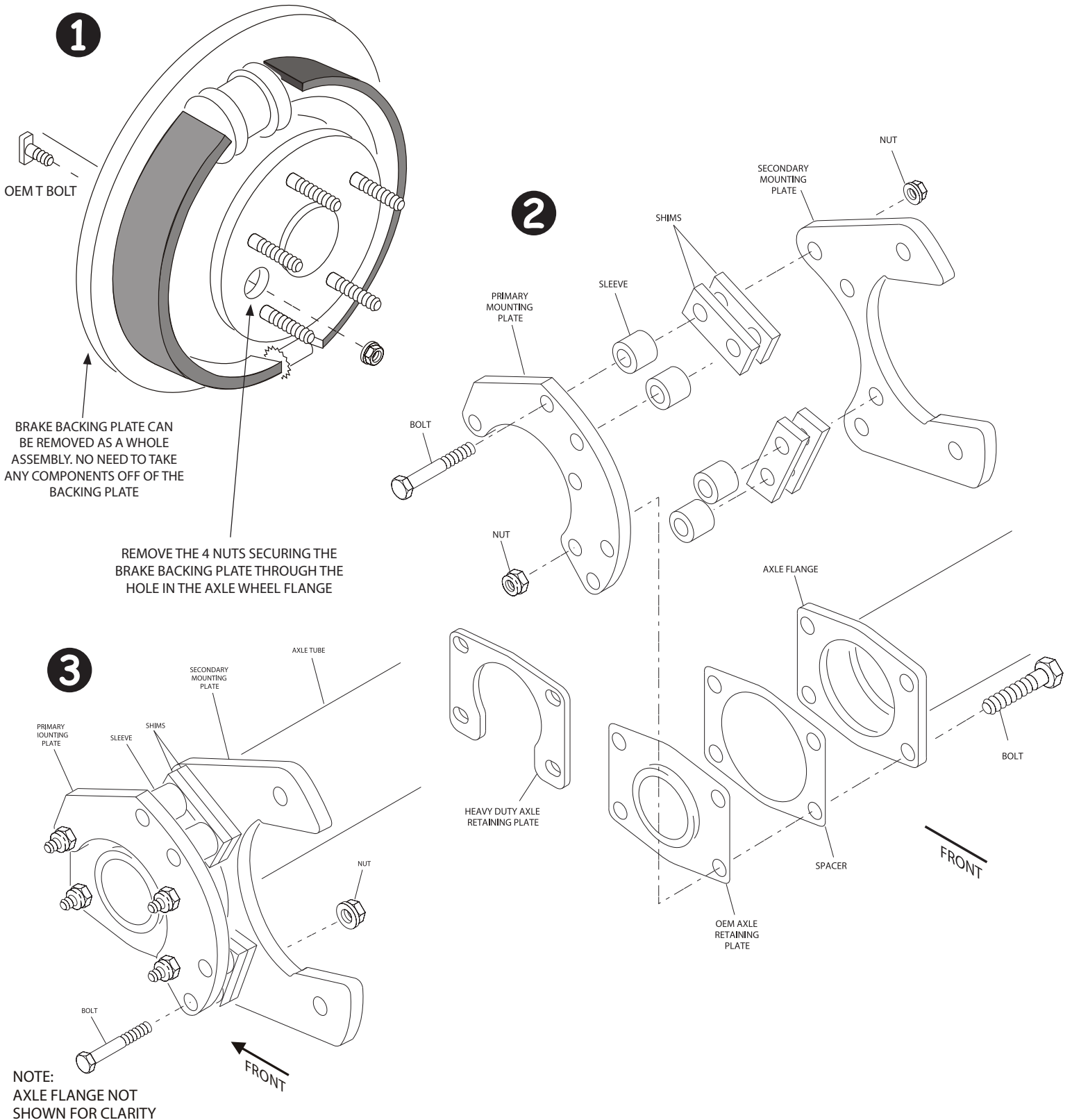

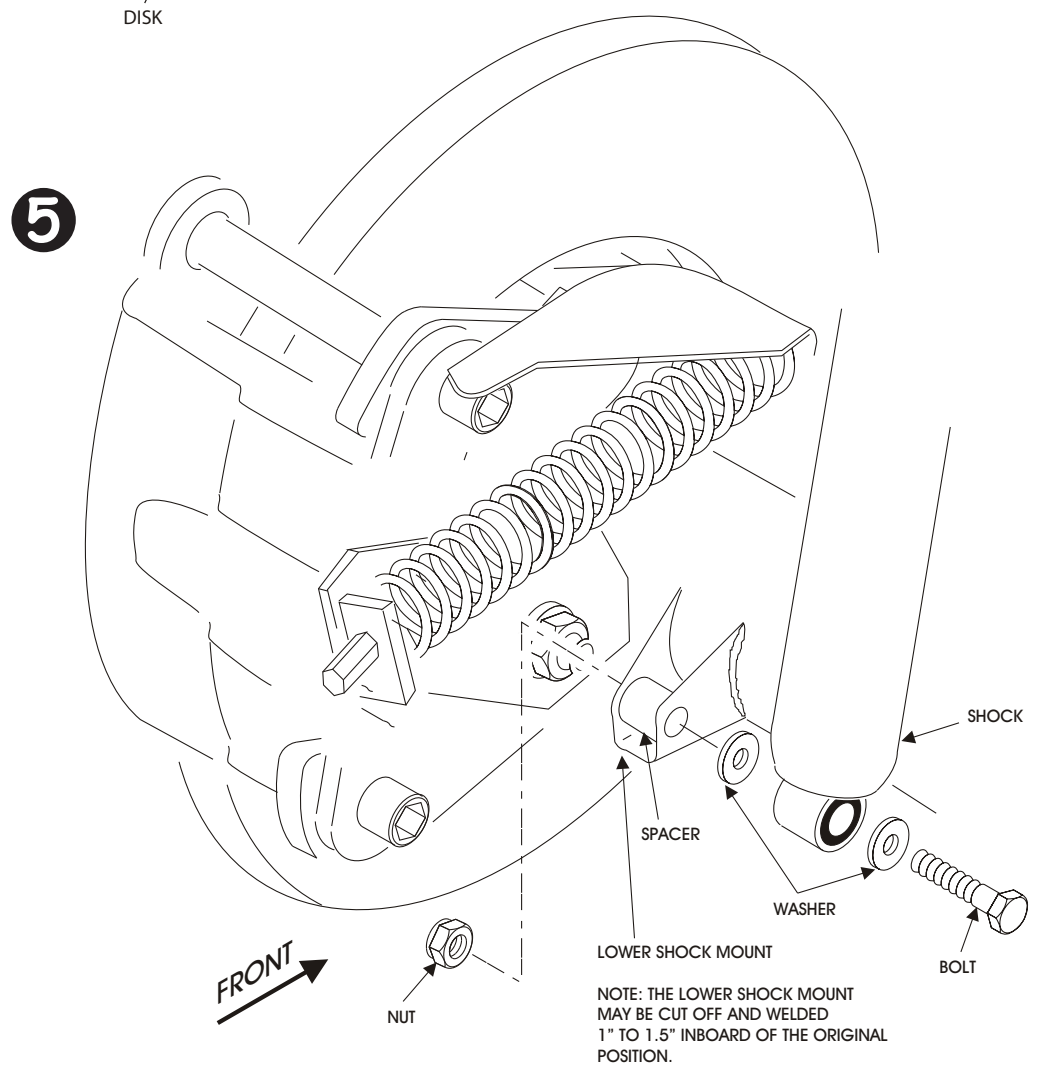
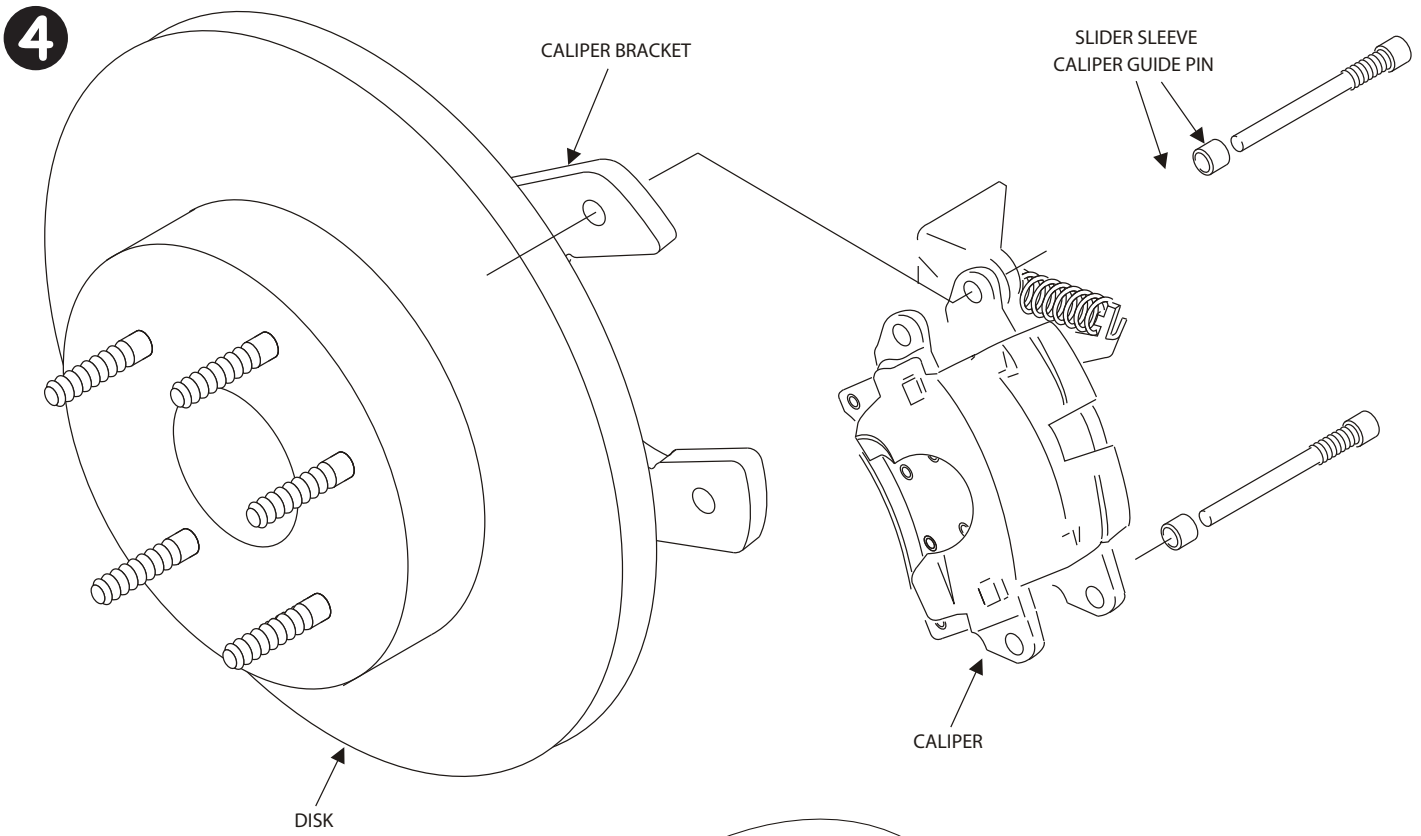

Mock up rear brake lines (small "S" line on driver side longer line to passenger side) to hose that is mounted to the top of the rearend housing. You can manipulate lines with slight bending to get them into position.

